



The EZ Series Slurry Pump

# Installation and Operating Manual

Excellence Pump Industry Co., Ltd.

## SAFETY INFORMATION

The following safety information relating to pump operation and maintenance should be carefully observed, and correct procedures followed, to avoid injuries to personnel, and damage to equipment. All statutory requirements relating to this equipment must be complied with at all times.

**DO NOT APPLY HEAT TO THE IMPELLER HUB OR INLET EYE TO ASSIST IMPELLER REMOVAL.** APPLICATION OF HEAT MAY RESULT IN SHATTERING OF THE IMPELLER, RESULTING IN INJURY OR EQUIPMENT DAMAGE.

**DO NOT OPERATE THE PUMP FOR AN EXTENDED TIME WITH ZERO OR VERY LOW FLOWRATE.** FAILURE TO OBSERVE THIS WARNING COULD RESULT IN OVERHEATING OF THE PUMP, AND VAPORISATION OF THE PUMPED FLUID, WITH GENERATION OF VERY HIGH PRESSURES. SERIOUS INJURY TO PERSONNEL OR DAMAGE TO EQUIPMENT MAY RESULT FROM SUCH ACTION.

**CHECK DRIVE MOTOR ROTATION PRIOR TO FITTING OF DRIVE BELTS OR COUPLINGS.** INCORRECT MOTOR ROTATION MAY CAUSE PERSONNEL INJURY OR EQUIPMENT DAMAGE.

**DO NOT FEED VERY HOT OR VERY COLD FLUID INTO A PUMP AT AMBIENT TEMPERATURE.** THERMAL SHOCK MAY RESULT IN FRACTURE OF PUMP WET-END PARTS.

**WHERE AUXILIARY EQUIPMENT IS ASSOCIATED WITH A PUMP.** (e.g. MOTORS, DRIVE BELTS, DRIVE COUPLINGS, SPEED REDUCERS, VARIABLE SPEED DRIVES, ETC), ALL RELEVANT INSTRUCTION MANUALS SHOULD BE CONSULTED, AND RECOMMENDED PROCEDURES IMPLEMENTED, DURING INSTALLATION, OPERATION AND MAINTENANCE OF THE PUMP SYSTEM.

**THE PUMP SHOULD NOT TURN UNDER LOW OR ZERO CAPACITY FOR LONG.** OTHERWISE THE PUMP MAY VIBRATE AND THE PUMP FLUID MAY VAPORIZE, WHICH MAY CREATE HAZARDS FOR PERSONNEL OR PROPERTY OR LEAD TO PREMATURE FAILURE OF THE PUMP.

**DO NOT WORK ON THE PUMP SET UNTIL THE ELECTRICITY SUPPLY HAS BEEN DISCONNECTED COMPLETELY AS THE PUMP IS A ROTARY OBJECT.** IT MAY CAUSE ACCIDENTS FOR PERSONNEL OTHERWISE!

**WHEN THE PUMP IS IN OPERATION, HANDS SHOULD NOT GET INTO OR REMOVE THE PROTECTIVE SHIELD OF THE PUMP.** IT MAY CAUSE ACCIDENTS FOR PERSONNEL OTHERWISE!

## **CONTENTS**

- I USES AND SCOPE OF APPLICATION
- II PATTERN, STRUCTURAL FEATURE OF PUMPS
- III SLING, INSTALLATION, ADJUSTMENT AND TEST RUN OF PUMPS
- IV COMMON FAILURE AND HANDLING MEASURE
- V MAINTENANCE AND DISMOUNTING OF PUMPS
- VI LIST OF QUICK-WEAR PARTS

## **ATTENTION**

1. The direction of motor must keep consistent with arrow on the Front casing. Before testing running the motor, the motor must be separated from pump. The shafts of Motor and pump are strictly forbidden to rotate reversely; otherwise some parts will be damaged.
2. Before operating the pump, the packing must be installed.
3. Before operation we must add oil (N32 summer or N46 winter) according to the oil level of oil gauge. Pump is strictly forbidden to operate without lube; otherwise bearings will be burned out.
4. When equipping the belt wheel of motor, the shaft of motor should manufactured in according to drawings provided if the shaft diameter is higher than 65mm so that the belt wheel operates safely.
5. Please read this technical manual carefully before installation and operation.

## I USES AND SCOPE OF APPLICATION

Type EZ series Slurry Pump is a new energy- saving centrifugal pump. The products are designed and developed by The Pump Technology Corporation, Hydro-mining Research Institute Tangshan Branch and Excellence Pump Industry Co., Ltd. They are innovative in hydraulic designs, structural designs and materials of castings after integrating congeneric products throughout the world. They have many features: high efficiency, reasonable design, reliable operation, longer service time, easy maintenance, and low running costs and so on. The EZ series pumps lead their domestic counterparts in various technical performances, with most of them approaching the advanced world level, and widely used for handling abrasive or corrosive slurries in power, metallurgical, mining, coal, as well as chemical industries. For example, flushing ash in power plants and pumping coal slurry in coal preparation plants. They are suitable for handling abrasive and corrosive solids-bearing slurry with maximum concentrations of wt. 45% (ash) and wt. 60% (ore).

## II PATTERN, STRUCTURAL FEATURE OF PUMPS

The EZ series slurry pumps are single-stage, single-suction, axial-suction and centrifugal slurry pumps. They are classified into the horizontal version (EZ type) and the vertical version (EZL type).

### 1. Structural feature and type of EZ slurry pumps

#### (1) Structural feature of EZ slurry pumps

##### Pump head:

It is a horizontal cantilevered slurry double-casing pump. The pump head includes cases, impeller, and shaft seal. Double-casing pump centrally split vertical split direction. Discharge port can be positioned at 8 different position at an interval of  $45^{\circ}$ . The outside cases made by HT200 or QT500-7, connecting with bolts. The inside cases (volute case, front liner, back liner) made by high-chrome alloy or natural rubber materials.

Impeller front and back cover plates with back vanes to reduce leakage and increase operating life, impeller and shaft is firmly connected by ladder-shaped with disassembly ring, "O" rubber ring is used between liner and volute casing and it is very convenient and reliable.

##### Shaft seal: expeller seal and packing seal

##### Support:

The supports can be lubricated by oil. Supports are made up with support body, support cover, shaft, bearing box, bearing, bearing cover, baffle sleeve, nut, oil seal wash plate and so on (See Figure, 1). The supports have water-cooling above 150EZ.

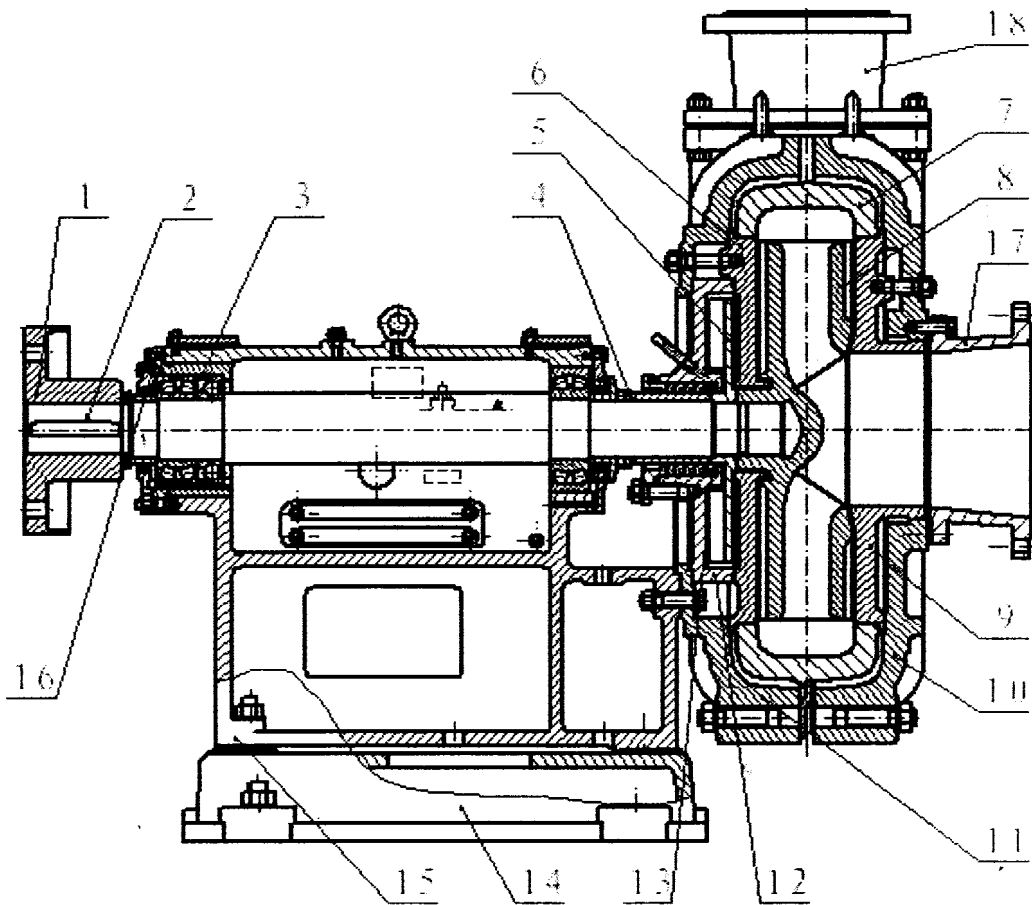

**Figure 1 Structural Drawing of EZ Slurry Pumps**

- |                     |                 |                      |
|---------------------|-----------------|----------------------|
| 1. Coupling         | 2. Shaft        | 3. Bearing housing   |
| 4. Disassembly ring | 5. Expeller     | 6. Rear liner plate  |
| 7. Volute casing    | 8. Impeller     | 9. Front liner plate |
| 10. Front casing    | 11. Rear casing | 12. Stuffing box     |
| 13. Water-seal ring | 14. Base        | 15. Support          |
| 16. Adjusting bolts | 17. Inlet stub  | 18. Outlet stub      |

(2). Notation of EZ slurry pumps

200 EZ-A60

200: Discharge diameter (mm)

E: Excellence Brand

ZJ: Slurry pump

A: Number of vanes of impeller (5)

60: Diameter of impeller (cm)

2. Structural feature and type of EZL series slurry pumps

(1) Structural feature of EZL series slurry pumps

EZL series slurry pumps are made up of Impeller, volute casing, rear line plate, shaft sleeve, support, Supporting plate, Shaft, Bearing, Bearing body and so on. The material of Impeller, Volute casing and Rear line plate is cast iron which contains high-chrome alloy. The impeller can be installed with shaft through screw thread. Volute casing, support and bearing body are connected with bolts. The driving patterns of the shaft and the motor could choose the coupling direct driven or the belt driven. The bearings of EZL slurry pumps are lubricated by grease. Structure of the EZL series slurry pumps (See Figure2).

(2) Type and meaning of EZL series slurry pumps

80EZL-36

80: Discharge diameter (mm)

E: Excellence Brand

ZJ: Slurry pump

L: Vertical type

36: Diameter of impeller (cm)

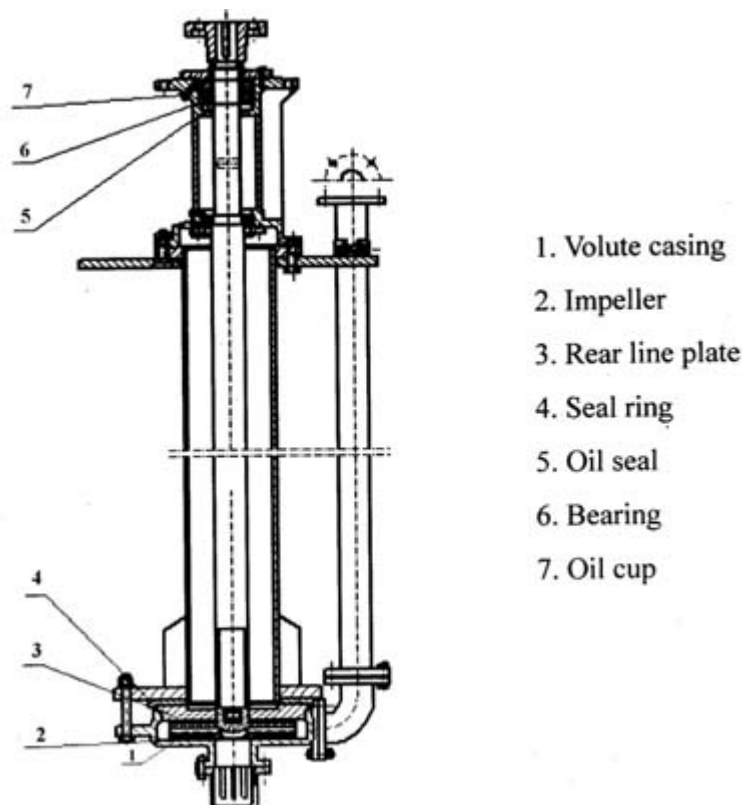

**Figure 2 The structural drawing of EZL series vertical slurry pumps**

### III SLING, INSTALLATION, ADJUSTMENT AND TEST RUN OF PUMPS

#### 1. Sling

When slinging a packed pump, we operate in accordance with marks on the packing case. The packing case shall avoid vibrating violently, over-inclining, landing on the body with pointed ends and being placed upside down.

When slinging an unpacked pump, we operate according as the following requirements:

(1). When lifting the horizontal pump without base or with singly base, the lift gravity is on the side of support square hole that near the pump head. Wire rope passes through this place to join with lift hook. In order to keep the balance of pump, the auxiliary wire rope should be added between inlet pipeline and lifting screw. The lifting screws on support cover and casings are assembled to dismount support cover and casings. They cannot be used when lift the whole pump in case of accident.

(2) When slinging the horizontal pump with motor and common base, the lift gravity is on the side of support square hole that near couplings. Wire rope passes through this place to join with lift hook. In order to keep the balance of pump, the auxiliary wire rope should be installed among inlet pipeline, lifting screws on motor and lift hook.

(3) The horizontal pump units with intermediate speed-transformation, such as coupled apparatus, should be lift separately.

(4) Cushion should be added between wire rope and body of pump to prevent damaging appearance of pump and cutting off wire rope.

#### 2. Installation

##### (1). Examination before installation

The pumps have been inspected and tested before ex-factory. Pumps should be set up correctly in order to possess good operating mode. We must check up types of pumps, parameters of pumps and components and parts in accordance with Packing List before installation. We ensure that technical data and quality certificate of pump is complete. Pump can be installed after reading correlation technical data carefully, especially such as this material and mastering related technical requirements

##### (2). Installation and capturing of pump

The horizontal pump units should be equipped by making use of twice grouting. The central line of pumps is consistent with the central line of foundation. The deviation between center-height of pump and design value is smaller than  $\pm 2$  mm vertically and 0.1/1000 horizontally.

We assure axis of pump units by adjusting couplings when pumps are drove by couplings. There are two methods. The first method is the use of knife ruler and plug gauge. We adjust outside diameter of couplings with knife ruler to guarantee alignment in every direction and the max tolerance ( $\delta$ ) less

than 0.1 mm [See Figure 3, (a)]. We examine the interval between couplings to guarantee the max tolerance  $\Delta$  ( $\Delta = \delta_1 - \delta_2$ ) smaller than 0.1 mm [See Figure 3, (b)]. The other method is the use of plug gauge and magnetic centigrade scale. We fix magnetic centigrade scale on outside diameter of one coupling and put measuring head on outside diameter of the other coupling. The pulsation of centigrade scale should be smaller than 0.15mm [See Figure 3, (c)] when turn rotor. We check up the space between couplings with plug gauge to ensure the max tolerance less than 0.1 mm [See Figure 3, (b)].

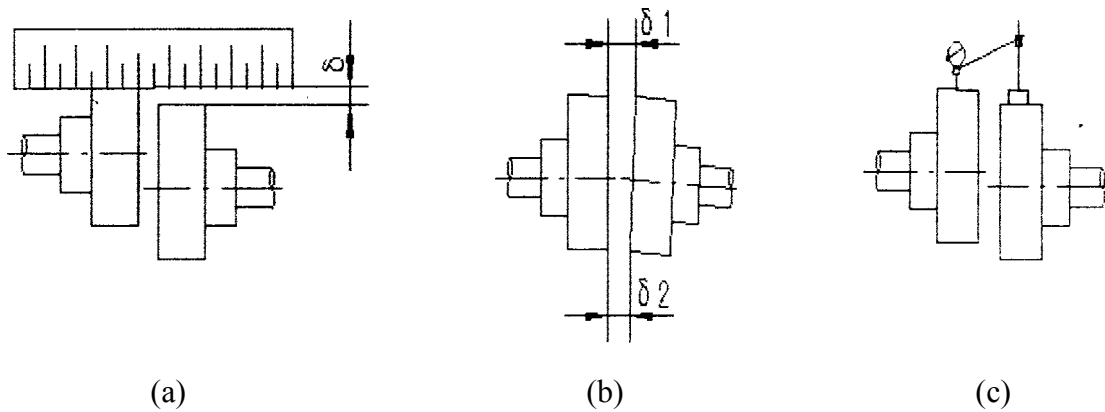

**Figure 3 Capturing of coupling**

The shaft of pump and the motor should assured the parallelism when pumps are drove by belts, so we adjust direction on the basis of pulley. When central distance is small, we can align end faces of pulley with ruler; when central distance is big. And we can adjust them by aligning end faces through span wire system [See Figure. (4)].

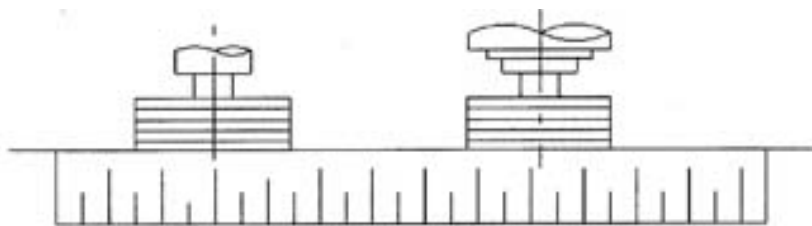
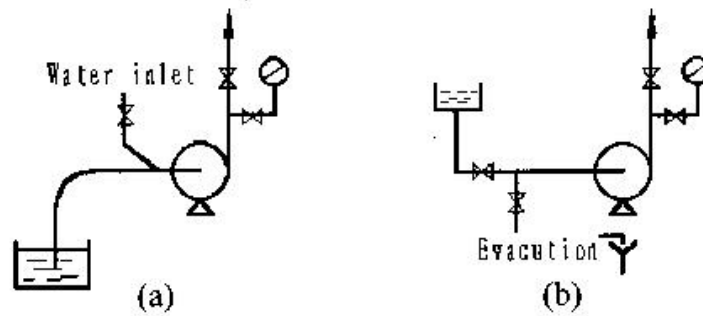

**Figure 4 Capturing of belt wheels**

### (3) Configuration and requirement of discharge pipeline and suction pipeline

According to the applied condition and the cavitation performance of pump, the arrangement of pump can be classified into exalted setting [See Figure 5, (a)] and low setting [See Figure 5, (b)].





**Figure 5 Arrangement of suction pipeline and discharge pipeline**

### ① Suction pipeline

Diameter of suction pipeline: diameter of suction pipeline should be equal to pump inlet or larger than it so as to avoid cavitation and deposition of slurry in pipeline.

Gate valve of suction pipeline: In order to maintain easily, we should install inlet gate valves whose diameter is equal to the diameter of suction pipeline. The expansion pipe should be set up between inlet of pump and suction pipeline so as to disassemble pump.

### ② Discharge pipeline

Diameter of discharge pipeline: diameter of discharge pipeline is usually bigger than outlet of pump because diameter of discharge pipeline is related to properties of slurries and sedimentation flow rate.

Gate valve of discharge pipeline: Diameter of outlet gate valve is equal to diameter of discharge pipeline.

Piezometer: the piezometer should be set up on the ascending pipe between outlet of pump and the first valve.

### ③ Points for configuration of pipeline.

The diameter of pipeline is related to system resistance, critical sedimentation velocity of slurry etc. Before inlet of pump, one-stage pipe longer than 3 times diameter of pipeline had better be installed. The velocity of slurry is between 1.5 and 3.0 m/s, which is determined by critical sedimentation velocity of slurry.

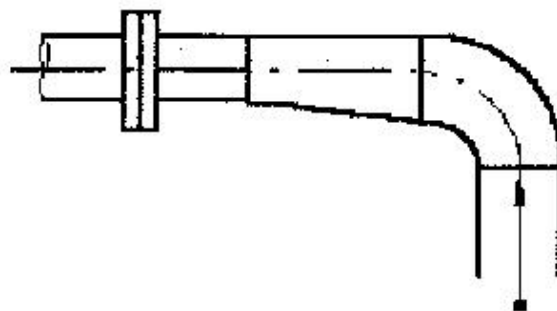

**Figure 6 Reducing pipe with horizontal upper generating line**

When we install suction pipe in suction arrangement we adopt pipe of varying diameter whose upper generating line is horizontal to avoid cavitation (See Figure6).

When we adjust the capacity of pump with throttle, should be installed on the discharge pipeline. When throttle is fixed on suction pipeline, cavity will happen easily.

(4) Pipelines of water-sealing and water-cooling

Packing seal will be equipped with stubs and piezometer. We must install pressure gauge on shaft seal water pipeline to adjust the pressure of shaft seal water. The setting of shaft seal water pipeline and water-cooling pipeline are seen on Figure7.

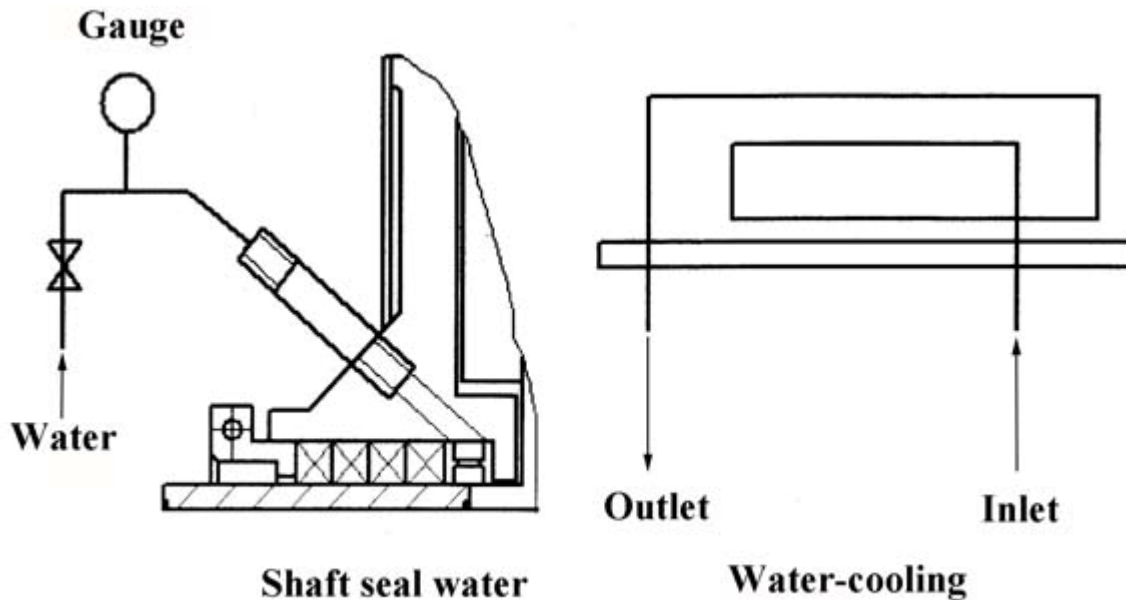

**Figure 7 Arrangement of shaft seal water pipeline**

The pressure of shaft seal water should be computed according as the following formula.

**Table 1 Pressure and Capacity of shaft seal water**

Shaft Seal	Pressure (MPa)	Capacity (m <sup>3</sup> /h)			
		G1/4"	G3/8"	G1/2"	G3/4"
Expeller seal and Packing seal	$P' = 0.5P_{out}$	1~1.5	1.5~2	2~3	3~5

Note: This Table is suitable to single stage pump.

When the suction pressure of pump is 0 ( $P_{in}=0$ ), the pressure of shaft seal water is equal to the half of the pressure of pump exit ( $P'=1/2P_{out}$ ).

The pressure of water-cooling is between 0.05-0.2MPa, the capacity is between 1-3 m<sup>3</sup>/h.

The type of water-cooling see Table 2.

Table 2 Type of Packing, water-sealing and water-cooling

No.	Pump Model	Packing (mm)	Pipeline (Water-sealing)	Pipeline (Water-cooling)
1	300EZJ-A100	22×22×636	G3/4"	G1/2"
2	300EZJ-A95			
3	300EZJ-A90	22×22×605	G3/4"	G1/2"
4	300EZJ-A85			
5	300EZJ-A70	19×19×502	G1/2"	G1/2"
6	300EZJ-A65			
7	300EZJ-A56			
8	250EZJ-A103	22×22×605	G3/4"	G1/2"
9	250EZJ-A96			
10	250EZJ-A90			
11	250EZJ-A85			
12	250EZJ-A83			
13	250EZJ-A80			
14	250EZJ-A78			
15	250EZJ-A75	19×19×502	G1/2"	G1/2"
16	250EZJ-A73			
17	250EZJ-A70			
18	250EZJ-A68			
19	250EZJ-A65			
20	250EZJ-A63			
21	250EZJ-A60	22×22×605	G3/4"	G1/2"
22	200EZJ-A85			
23	200EZJ-A75			
24	200EZJ-A73			

No.	Pump Model	Packing (mm)	Pipeline (Water-sealing)	Pipeline (Water-cooling)	
25	200EZJ-A70	19×19×455	G1/2"	G1/2"	
26	200EZJ-A68				
27	200EZJ-A65				
28	200EZJ-A63				
29	200EZJ-A60				
30	200EZJ-A58				
31	150EZJ-A70				
32	150EZJ-A65				
33	150EZJ-A63				
34	150EZJ-A60				
35	150EZJ-A58				
36	150EZJ-A55				
37	150EZJ-C58				
38	150EZJ-A57				
39	150EZJ-A50	16×16×364	G1/2"	G3/8"	
40	150EZJ-A48				
41	150EZJ-C42				
42	100EZJ-A50				
43	100EZJ-A46				
44	100EZJ-A42	13×13×308	G1/2"	G3/8"	
45	100EZJ-A39		G3/8"	G1/2"	
46	100EZJ-B42		16×16×364	G1/2"	G3/8"
47	100EZJ-A36				
48	100EZJ-A33				
49	80EZJ-A52	13×13×308	G1/2"		
50	80EZJ-A42				
51	80EZJ-A39	13×13×308	G3/8"		
52	80EZJ-A36				
53	80EZJ-A33				
54	65EZJ-A30	10×10×226	G1/4"		
55	65EZJ-A27				
56	50EZJ-A50	16×16×364	G1/2"	G3/8"	

No.	Pump Model	Packing (mm)	Pipeline (Water-sealing)	Pipeline (Water-cooling)
57	50EZJ-A46	13×13×308	G1/2"	G3/8"
58	50EZJ-A33	10×10×226	G1/4"	
59	40EZJ-A17	8×8×163	G1/4"	

### (5) Packing selection

Asbestos packing with mica should be often used when the working pressure of pump is less than 0.5MPa and asbestos packing with polytetrafluoroethylene should be used when the pressure is more than 0.5Mpa. The type of packing see table 2.

The packing standard should be accord with stuffing box size, and from the direction of shaft, joints of the adjacent packing rings included 120°

### 3. Adjustment of pump

We examine and adjust pumps after assembly.

(1) Adjustment of the interval between impeller and front liner (See Following)

(2) Adjustment of rotation direction of motor

Motor's direction of rotation must be in accordance with pump's direction of rotation. When pump operate in opposite direction, some parts will be damaged. After pumps are divorced from motors completely, we can regulate motor direction of rotation. When they are in the same direction, we attach pumps to motors. We must not start motor blindly.

(3) Adjustment of transmission

When pumps are driven by elastic pin coupling, protective cover and pins should be set up carefully. When pumps are drove by belt, we adjust sliding track so as that every belt has the same pretightening force and install protective cover attentively. When pumps are drove by speed controllers, they are adjusted according to installation instructions.

(4) All of fasteners must be reinforced again.

(5) Put the tools and the lumbers aside to avoid accident, which was set on pump units

### 4. Test run of pumps

Pump sets can be tested run after adjustment. If possible, slurry can be transported after test run with clear water.

(1) Starting of pump

① Before starting of pump we must turn the impeller around in the stated direction in order that whether running is flexible.

② Switch on shaft seal water. Adjust pressure up to specified value.

③ Suction valves are opened completely.

④ Open water-flooding valves to pour the water into pump.

⑤ Open the outlet valves and adjust the opening degree of valve gate to quartet.

⑥ Start the pump units. We turn on piezometer on discharge pipeline after speed of rotation was stable. If pressure of discharge pipeline was stable, we can open discharge valves slowly up to required working conditions.

Attention: When discharge valves are opened fully, starting pumps will make motor overloaded. Opening suction valves partly will bring about cavity.

#### (2) Notes of pump

After operation of pumps normally, we should examine the following

① Examine whether the capacity and head of pump stable and fit for requirement of work condition.

② Examine whether the electric current of motor is stable.

③ Examine sound, noise and vibration in pump units is normal or not.

④ The temperature rise of bearings is under  $35^{\circ}\text{C}$ , but the highest temperature of bearings is lower than  $75^{\circ}\text{C}$ .

⑤ For packing seal, should open the shaft sealing water and check whether shaft sealing water quantity and water pressure are suitable, adjust the bolts on packing gland so as to adjust packing and shaft sealing water, it is better to leak out drop by drop, if packing is very tight, heating will be produced on the bearing consuming power, if packing is very loose, amount of liquid leakage will be excessive large.

#### (4) Shutting down

① Pumping clear water on pump for 30 minutes before shutting down in order to clear any slurry through pump.

② Shut off discharge valves.

③ Close the water of shaft seal and water-cooling.

④ Shut off suction valves.

Attention: We must stop each stage pump at the same time when discharge valves are opened fully, lest water hammer happen and parts will be damaged.

## IV COMMON FAILURE AND HANDING MEASURE

### No.1

#### (1) Appearance of faulty

There is no water in pipeline when pumps operated normally. The pointers of pressure gage and vacuum meter move up and down violently.

#### (2) Analysis of reason

a. There is not enough water in suction pipeline.

- b. Pipeline is blocked up and suction valves are not opened completely.
- c. There is a serious leakage of air in suction pipeline、apparatus、stuffing box etc.

(3) Processing measure

- a. We fill water into suction pipeline.
- b. Open suction valves and clean plugging cement in pipeline.
- c. Stop a leakage of air.

**No.2**

(1) Appearance of faulty

There is no water in pipeline when pumps operate normally. The vacuum meter shows high vacuum.

(2) Analysis of reason

- a. The suction valves are closed or stopped up.
- b. The resistance of pipeline is too big. Pipeline is stopped up.
- c. The mounting height is too high.

(3) Processing measure

- a. Open suction valves or clean dirt.
- b. We improve the suction pipeline design or clean dirt.
- c. We can lower mounting height.

**No.3**

(1) Appearance of faulty

There is no water in pipeline when pumps operate normally. The pressure gages show a little pressure.

(2) Analysis of reason

- a. The resistance of discharge pipeline is too high.
- b. Impellers are clogging.
- c. Rotation speed of pump is smaller.

(3) Processing measure

- a. We examine and adjust discharge pipeline.
- b. Clean impellers.
- c. Improve rotation speed of pump.

**No.4**

(1) Appearance of faulty

The pump cannot rotate normally.

(2) Analysis of reason

- a. There are blocks in volutes.

b. Outlet valve doesn't closes fully and slurry was put into pump.

(3) Processing measure

a. Clean dirt in volutes.

b. Examine and replace valve and clean dirt.

#### **No.5**

(1) Appearance of faulty

The capacity of pump is not enough.

(2) Analysis of reason

a. impeller, discharge pipeline , and suction pipeline are blocked up.

b. expellers are worn down.

c. reunion speed of pump is smaller than designed value.

d. installation is unreasonable. There is a leakage of air in suction pipeline.

e. The resistance of pipeline is too high.

f. Suction valves are opened partly.

g. Pumps are unfit for working condition.

(3) Processing measure

a. Clean impellers and pipeline.

b. Exchange impellers.

c. Readjust rotation speed of pump motors.

d. Remount pumps and reduce a leakage of air.

e. Lower height of transport. Reduce resistance of pipeline.

f. Open suction valves completely.

g. Choose pumps again.

#### **No.6**

(1) Appearance of faulty

Motors are overloaded.

(2) Analysis of reason

a. Delivery head of pump is higher than necessary head, so value of working condition moves to the larger capacity.

b. Proportion of slurry is not considered when we choose motors.

(3) Processing measure

a. Cut down impellers. Bring down rotation speed of pump.

b. Choose motor again.



**No.7**

(1) Appearance of faulty

There is no water in pipeline. Sound in pump is abnormal.

(2) Analysis of reason

- a. Resistance of suction pipeline is too high.
- b. Height of suction is too large.
- c. Cavitation happens.
- d. Air goes into suction pipeline.
- e. The temperature of slurry is high.

(3) Processing measure

- a. Clean suction pipeline and inlet gate valves.
- b. Bring down height of suction,
- c. Adjust discharge valves so as that flow of pumps goes into the prescribed limit.
- d. reduce the leakage of air.
- e. bring down the temperature of slurry.

**No.8**

(1) Appearance of faulty

Pumps vibrate violently.

(2) Analysis of reason

- a. Cavitation happens.
- b. Expellers are blocked up.
- c. The shaft of pump and the shaft of motor are not concentric.
- d. Fastening parts or foundation becomes flexible.

(3) Processing measure

- a. Bring down height of installation. Lessen the resistance of suction pipeline.
- b. Clean the impellers.
- c. Readjust central line again.
- d. Fasten anchor nuts and reinforce ground.

**No.9**

(1) Appearance of faulty

Bearings have a fever.

(2) Analysis of reason

- a. Cooling water cocks are not opened.
- b. Bearings cannot be lubricated normally.

- c. Lubricant oil is not clean.
  - d. The installation direction of thrust bearing is not proper.
  - e. Quality of bearing is not up to standard.
- (3) Processing measure
- a. Turn on cooling water.
  - b. Adjust oil level according to specification instructions.
  - c. Clean bearings and replace lubricant oil.
  - d. Determine installation direction of bearing according to direction of pressure.
  - e. Change bearings.

**No.10**

- (1) Appearance of faulty
- a. Excessive leakage from stuffing box.
  - b. Packing was burned down.
- (2) Analysis of reason
- a. Packing worn.
  - b. No water-sealing
- (3) Processing worn.
- a. replace new packing
  - b. open the water-sealing.

**No.11**

- (1) Appearance of faulty
- Oil is leaked from pump.
- (2) Analysis of reason
- a. Oil level is too high.
  - b. Seal parts loss efficacy.
  - c. Pumps are assembled unreasonably.
- (3) Processing measure
- a. Bring down oil level.
  - b. Exchange seal parts.
  - c. Reassemble pumps.

**No.12**

- (1) Appearance of faulty

Water is leaked from pump head.

(2) Analysis of reason

a. There are questions in rubber parts.

(3) Processing measure

a. Press rubber parts or reassemble pumps.

## V MAINTENANCE AND DISMOUNTING OF PUMPS

In order that EZ series pumps operate safely and play to strong points, maintenance and way of disassemble & assemble is important. According to the feature of the EZ series pumps, we establish the requirement of maintenance. When the pump is working, must ensure that the packing are installed.

### 1. Maintenance

The EZ series pumps have been adjusted before delivery. During 6 months after purchasing customers need not take apart pumps. Before using pumps, we should examine the flexibility of rotation and add lubricant oil.

(1) Keep facilities clean, dry, without dirties and leakage.

(2) Examine oil level in support every day, its deviation from the oil level of support is  $\pm 2$  mm.

(3) Examine operation、vibration and leakage every day. We must solve them in time when we find problems.

(4) No operating when pump-out. When operating on that condition, pumps will vibrate violently and reduce service life.

(5) Metal body and big block, which cannot pass through pumps, must not enter pumps. Neither do rubbers, plastics, and cottons, lest wet parts are damaged and stopped up so as to operate abnormally.

(6) We should check up flow and pressure of shaft seal water and cooling water and oil by examining position of valves and taking their temperature of stuff box. Higher temperature shows short of water.

(7) Examine leakage of shaft seal water regularly. When leakage becomes big we should adjust bolts of stuff cover and exchange stuff in time.

(8) Assembly of the packing

①The packing length should be accord with sleeve circle, and from the direction of shaft, joints of the adjacent packing rings crossed  $120^\circ$ .

②After packing, test run with supplying water, meantime, adjust gland bolts carefully to make the leakage be drop not line. Packing is very important to be pay attention to, it not only related state of seal, but also affect performances of pump.

(9) In order to make pumps operate efficiently we must adjust the interval between impeller and front liner so as that it is between 0.75-1.00 mm. The interval has been adjusted before delivery. You can stop pump and adjust it if you find it isn't up to mustard or you find problem in pump's work. Adjust

them as following.

- ① Undo nuts of support cover.
- ② Undo adjustable bolt screws.
- ③ Tighten nuts of bearing box averagely so as that rotor moves to pump head until rotor cannot rotate. Attention: direction of winding impellers should be in accordance with work direction.
- ④ Measure the interval ( $\delta = a$ ) between flange of bearing box and end face of support. Now the interval between impeller and front line is zero.
- ⑤ Undo nuts of bearing box.
- ⑥ Tighten adjustable screws averagely so as that rotor moves to motor. Check up the interval until it is equal to  $a+(0.75-1.00\text{mm})$ . Attention: ensure the rotor stated firmly.
- ⑦ Tighten nuts of bearing box in order to fix rotor in axial direction.
- (10) Examine temperature of bearings and ensure it lower than 75C.
- (11) Exchange lubricating oil after pumps operate for 800 hours running.
- (12) Auxiliary pumps rotate the quarter circle weekly so as that shaft of pumps bears static load and vibration of base evenly.
- (13) If auxiliary pumps are not operating for a long time, we should clean sediment with water before running pumps.
- (14) Examine supporting mechanism of pipeline regularly so as that supporting is reliable and body of pump does not bear supporting force.
- (15) examine fastening parts of base frequently in order that lasting is reliable.
- (16) Pins can be set up after testing rotor direction of rotation for pumps assembled just now and repaired. Belts can be set up after testing motor direction of rotation when pumps are drove by belts. Pumps must not rotate oppositely. When motors are loss of power, slurry in pipeline can make impellers rotate oppositely. But when head of pump is above 80m, we should prevent slurry from flowing back lest pumps rotate oppositely.
- (17) Before starting pumps, we should switch on shaft seal water and cooling water. After stop pumps for 15 minutes, we switch off shaft seal water and cooling water.

## 2. Assembly、dismantlement and examination

All elements and parts should be checked up and washed before assembly. We examine if all elements and parts are fit for requirement. After exchanging damaged parts, we assemble pumps.

Sequence and requirement of assembling

### (1) Assembly of rotor parts

Bearings in the EZ series Slurry pumps are made in China generally. And the system of lubrication applies to oil.

- ① Assembling of bearing
  - a. Use qualified bearings.

b. Examine depth of parallelism and degree of roughness of inner diameter、 outer diameter, width and two end faces. Check up flexibility of rotation、 rust、 stain and so on.

c. We should check up the endplay to angle joint bearing and double self-aligning bearings. After we find the center of ball track, we determine whether to add washer and what deep the washer is to guarantee the standard endplay of bearings. Don't assemble radial thrust bearing contrarily.

d. When we assemble separable bearings, we should set up them according to marks of inner rings and outer rings in order to avoid assembling them improperly.

e. For bearings that can be installed in double direction, we should make the end with marks outward so as to recognize.

#### ② Assembly of shaft

a. To avoid occlusion of seating and damaging axle holes, we should smear oil on seating before installation.

b. We install bearings by using hot-pack method. We put bearings into oil into heating apparatus to immerse all seating into oil. We heat the oil to 80-100 °C. We should install thermometer in oil to control temperature. After installation, bearings should be cooled down naturally to avoid damaging elements and deforming elements.

c. after installing back bearing, we assemble the baffle sleeves and knuckle nuts to press bearing.

d. After examining whether bearings lean on shaft shoulder and whether bearings rotate flexibly. After that, assemble bearing box as hot-pack method.

e. Assemble front bearings last as above.

f. Fix the seal rings on bearing box.

g. After parts of shaft and support are installed, assemble other parts as assembly drawing.

#### (2) Assembly of support

Above all, clear support cover、 support body's oil pool and bearing hole.

① After we clean the seating between support cover and support body we add paper washer to guarantee bearing holes fit for tolerance of  $\pm 0.015\text{mm}$ .

② We assemble hexagonal plug screw and oil scale-plate. We scratch a line through the center of oil scale-plate and smear red paint to express oil level.

③ Assemble cooling parts and cooling cavity covers (Note: Some pumps are not equipped with cooling cavity covers.).

#### ④ Assembly of parts of shaft and support

Lift shaft and put parts of shaft into seating of support. Lift support cover to close support after swearing glue on paper washer. Interval between inner end face of bearing box and end face support is 3mm. We set up taper pin and tighten bolts in advance.

⑤ Set up oil seal in front bearing cover. After add washer between front bearing cover and end face support, we can tighten bolts.

⑥ After we examine the interval between back bearing cover and bearing box, we can repair depth of covers and add cushion to let bearing cover leave on the bearing closely. We install oil seal in back bearing cover and tighten bolts after adding cushion between back bearing cover and end face of support.

⑦ Assemble wash plate and discharge ring. Before assembling discharged ring and pressing wash plate tightly, we should fill grease into screw hole.

⑧ Assemble adjustable nuts and adapter screw bearing box.

⑨ Magnetic centigrade scale is equipped with, shaft so as to measure coaxality and perpendicularity between locating hole and end faces、shaft center of gyration. The tolerance is smaller than 0.25mm.

⑩ Assemble coupling or pulley.

### (3) Assembly of rear casing and rear liner plate

① assemble rear casing on the support.

② assemble sleeve within seal rubber ring on the shaft, then assemble packing gland and water-seal ring on sleeve.

③ assemble stuffing box and seal ring in trough, and expeller seal ring and expeller.

④ assemble hook-like bolts in rear liner plate first. Lift rear liner plate and assemble on rear casing, tighten bolts. Measure the interval between rear liner plate's endo-hole and expeller's hub and examine it if equal. Check up if there is rub when barring.

### (4) Assembly of impeller and volute

① After swearing oil on screw, we assemble impeller on shaft and press space sleeve tightly.

② Press bolt on machine seal cover.

③ Assemble seal ring on back liner.

④ We assemble volute on back liner after lifting volute. Then we tighten bolts.

### (5) Assembly of front casing and front liner plate

① Fit hook-like bolts into front liner plate, and lift front liner plate in front casing which is horizontal on the ground, then connect them with bolts.

② Assemble front liner plate seal ring and lifting bolt on front casing.

③ Lift parts of front casing and front liner plate, and push the cone-circular of front liner plate into bore-hole of front casing. Tighten all the boles after the space of volute casing and front casing's outlet top surface is 5mm.

④ Adjust the space between impeller and front liner plate is between 0.75-1.00mm, the methods as the previous.

### (6) Assembly of inlet and outlet stubs

① After adding cushion of 3mm between stubs and volute, we tighten bolts. If rubber cushion is not pressed tightly we must thicken rubber cushion. Make sure the space between inlet (outlet) flange

and pump case's inlet (outlet) top surface smaller than 1 mm.

② In order to disassemble easily, assemble telescopic joint in front of inlet stub.

③ Shaft should be rotated by hand to insure that the impeller rotates with shaft freely without friction noise.

(7) Assembly of other elements

① Assemble coupling or belt.

② After spotting between motor and pump, we test rotation of motor. Then we assemble pins and rubber ring or belt.

③ Assemble cover of coupling and pulley.

filling packing accords to the rules.

(8) test run

When testing run we check up vibration, temperature, leakage and so on. And adjust packing to be right timely.

## VI LIST OF VULNERABLE PARTS

No.	Component	Part	Nos.	Material
1	Head	Impeller	1	
2		Impeller	1	
3		Front liner plate	1	
4		Rear liner plate	1	
5		Stuffing box	1	
6		Expeller	1	
7		Water-seal ring	1	
8		Shaft sleeve	1	
9		Inlet stub	1	
10		Outlet Stub	1	
11		Packing cover	1	
12		“O” rubber ring	6	
13	Support	Bearing cover	2	
14		Bearing	2	
15		Oil seal	3	
16		Baffle sleeve	1	
17		“O” rubber ring	2	
18		Bearing housing	1	
19		Wash plate	1	
20		Disassembly ring	1	
21		Shaft	1	
22		Cooler	1	



**Headquarter:**

Add: No.368, Xinshi North Road, Shijiazhuang, Hebei, China 050091.

**Beijing Branch:**

Add: No.78, East 4th Ring Middle Road, Beijing, China 100124.

Tel: +86-10-81107022

Fax: +86-10-81107016

For inquiries, please send your emails to [sales@excellencepump.com](mailto:sales@excellencepump.com)

For customer service, please send your emails to [service@excellencepump.com](mailto:service@excellencepump.com)